



Dump trailer, hydraulic rear model with container made of stainless steel AISI 304



Mod. AF RR INOX

**COSTS OF
BRAKING SYSTEM
TO BE ADDED**

- Equipped with a frame made of steel
- With tandem axles
- Hydraulic unloading at the rear with quick coupling operation of the tractor with endstroke valves
- Height-adjustable towing eyelet
- Adjustable hydraulic support foot
- Container made of stainless steel AISI 304, thickness 25dm
- Rear tailgate with hydraulic opening with coupling operation
- Front-rear para fluids
- Hydraulic cylinders to stop the compensating tandem system
- Hydraulic cylinder to discharge the container with end-of-stroke valve
- EC certificate
- NB: 4 hydraulic double effect jacks

Mod.	LENGTH	WIDTH	HEIGHT CONTAINER	TYPE OF TANDEM	TYRES	BRAKING SYSTEM	TARA	CAPACITY M ³
AF RR INOX 40x20	400	200	120	fixed compensating system	355/5 R 22,5 used	hydraulic, or pneumatic	2200	8,5
AF RR INOX 40x20 S	400	200	120	steering compensating system	355/5 R 22,5 used	hydraulic, or pneumatic	2900	8,5
AF RR INOX 45x20	450	200	120	steering compensating system	355/5 R 22,5 used	hydraulic, or pneumatic	3200	10
AF RR INOX 50x20	500	200	120	steering compensating system	355/5 R 22,5 used	hydraulic, or pneumatic	3600	12
AF RR INOX 50x23	500	230	120	steering compensating system	355/5 R 22,5 used	hydraulic, or pneumatic	3600	13,5
AF RR INOX 55x23	550	230	120	steering compensating system	355/5 R 22,5 used	hydraulic, or pneumatic	4500	15,0

NB: Height container (C) 140

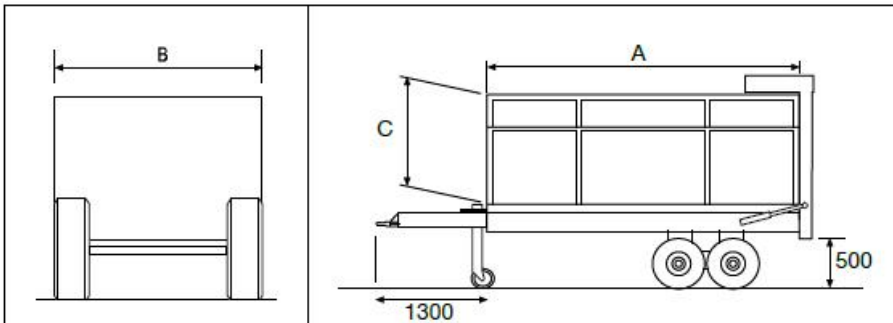

Pump with oil tank and universal joint

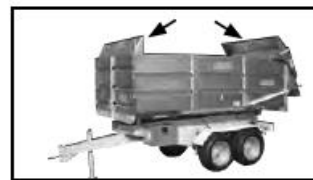

central para fluids



Pneumatic braking system
8000-10000-12000-14000 kg
PN 008



Hydraulic braking system
with tractor pedal if
supplied
8000-10000-12000-14000 kg
PN 020